

**NEW!**

# C to X Adapter

Get the best of both worlds  
NOW IN ONE GUN AND TWO ADAPTERS

**PRO SPOT**  
PATENT PENDING



from  
**C**  
to  
**X**  
in 15 sec.

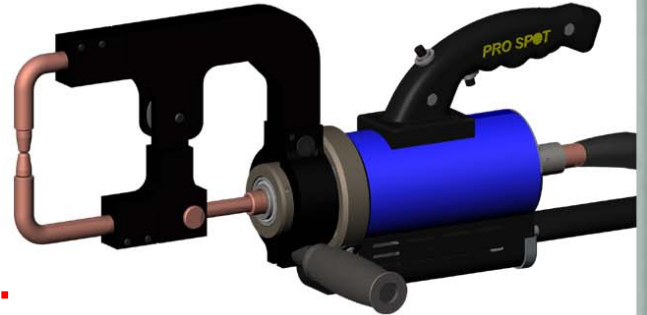

No assembly needed. No cables needed.  
The current is transferred via a pivoting copper conductor  
which also allows for the build up of squeeze pressure.

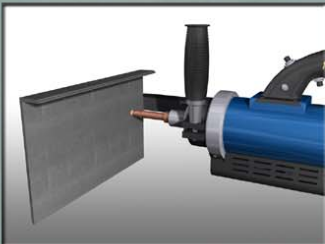

#### C-TYPE GUN - ERGONOMICALLY CORRECT

The advantage of the C-Type spot gun is that when welding vertical pinch welds such as quarter panels, rocker panels, door pillars, etc., the spot gun is positioned perpendicular to the work area. Easy to reach and easy to use!



#### X-TYPE GUN

The X-type design is used on certain applications where the C-type can't reach. 90% of all welding needs can be done with the C-type but for some radiator support and truck bed pinch welds, the X-adapter is priceless.

This new invention from Pro Spot now makes it possible to weld where you never could before!

#### Different electrode arms

